

Speed Dome 66 User's Manual

Table of Contents

1	FEATURES AND FUNCTIONS	7
1.1	General Introduction	7
1.2	Feature	7
1.2.1	On-Screen Menu	7
1.2.2	Support multiple protocols	7
1.2.3	Proportional Pan and Tilt	7
1.2.4	On-screen Tips	7
1.2.5	Preset Setup and Recall	7
1.2.6	Auto Scan	7
1.2.7	Auto Touring	8
1.2.8	Auto Pattern	8
1.2.9	Privacy Masking	8
1.2.10	Action on Alarm	8
1.2.11	Auto Flip	8
1.2.12	Self-diagnosis	8
1.2.13	Day/Night Mode (B/W & Color Mode)	8
1.2.14	Auto Focus	8
1.2.15	Backlight Compensation	8
1.2.16	Pan Tilt and Zoom	8
1.2.17	3D Intelligent Location	8
1.2.18	Idle Status	9
1.2.19	Image Stabilizer/Flip	9
1.3	Specification	9
2	PROTOCOL, BAUD RATE, ADDRESS SETUP	11
2.1	Protocol and Baud Rate Setup	11
2.2	Set address dial switch	12
3	CABLE CONNECTION	13

3.1	RS485 and Power Cable Connection	13
3.2	Alarm Cable Connection	14
3.2.1	System Layout.....	15
3.2.2	Alarm Connection.....	16
3.2.3	Keyboard Connection	16
4	MENU	18
4.1	Screen Menu Index.....	18
4.2	System Information	19
4.3	Main Menu	19
4.4	Menu Operation.....	20
4.4.1	Dome System Information.....	20
4.4.2	Display Setup.....	21
4.4.3	Camera Setup.....	22
4.4.4	Function Setting.....	23
4.4.5	Alarm Setup	30
4.5	Dome Abnormal Phenomenon Operation	31
4.5.1	Restore to Factory Default Setup	31
4.5.2	PTZ Movement is not smooth	31
5	FAQ.....	32
5.1	Daily Maintenance	32
5.2	Problems and Solutions.....	32
6	APPENDIX I THUNDER PROOF AND SURGE PROTECTION.....	33
7	APPENDIX II ABOUT RS485 BUS.....	34
7.1	RS485 Bus Main Feature	34
7.2	RS485 Bus Transmission Distance.....	34

7.3	Connection Methods and Terminal Resistance	34
7.4	The Problem in Practical Use.....	35
7.5	RS485 Bus FAQ.....	36

Welcome

Thank you for purchasing our product!

This user's manual is designed to be a reference tool for the operation of your system.

Here you can find information about this speed dome features and functions, as well as a detailed menu tree.

Before installation and operation, please read the following safeguards and warnings carefully!

Important Safeguards and Warnings

1 . Electrical Safety

All installation and operation should conform to your local electrical safety codes. We assume no liability or responsibility for all the fires or electrical shock caused by improper handling or installation

2 . Transportation Security

No heavy stress, violent vibration or water splash are allowed during transportation, storage and installation.

This series product must use split type package during the transportation.

We are not liable for any damage or problem result from the integrated package during the transportation.

3 . Installation

Keep upwards. Handle with care.

Does not touch the lower dome cover; it may affect the video quality,

Do not apply power to the dome before completing installation.

4 . Qualified Engineers Needed

All installation here should be done by the qualified engineers.

All the examination and repair should be done by the qualified service engineers.

We are not liable for any problems caused by unauthorized modifications or attempted repair.

6 . Environment

This product has been tested and found to comply with the IP67 standard of Degrees of protection provided by enclosure (IP Code).

The dome should be installed in a cool, dry place away from direct sunlight, inflammable, explosive substances and etc.

7 . About Camera

Camera should be installed away from direct sunlight or other strong artificial lights to avoid blooming and smear.

When the camera is aiming at bright light or object, such as spotlight or sun, smear or blooming may appear.

Only use mild detergent or dry cloth to clean the camera.

8. About Accessories

Always use all the accessories recommended by manufacturer.

Before installation, please open the package and check that all the components are included in the package:

Contact you local retailer ASAP if something is missing in your package.

1 Features and Functions

1.1 General Introduction

This series product is an integrated high intelligent speed dome. It adopts water drop configuration design and has small and delicate shape. This is a digital and intelligent product of vivid video. The installation is convenient.

The built-in PTZ adopts Ampnet socket quick installation. It supports various languages, clock function and protocol auto recognize.

It supports 360° continuously pan, 92° tilt and 180° auto flip. It can realize no blind spot monitor.

This series product can be widely used in remote monitor environment such as electric power, customs, water conservancy, bank and large enterprises.

1.2 Feature

This series speed dome has the following features:

1.2.1 On-Screen Menu

This series product menu supports multiple languages.

It is easy for you to view dome information and configure dome, camera parameters.

1.2.2 Support multiple protocols

This series speed dome supports universally used protocols such as PELCO-P and PELCO-D. You can use various devices (such as matrix, control keyboard and DVR) and protocols to operate speed dome.

1.2.3 Proportional Pan and Tilt

This function keeps the image from moving too fast when there is a large amount of zoom.

Speed dome continually decreases or increases pan and tilt speeds in proportion to depth of zoom. When zooms speed is increasing, the camera moving speed becomes slow. When zooms speed is decreasing, the camera moving speed becomes fast.

1.2.4 On-screen Tips

Here you can view:

- Dome title and system version (Software and hardware)
- Dome system temperature. (Optional. You can disable this function)
- Dome protocol, baud rate, address.
- Dome pan/tilt coordinates, preset ID.

1.2.5 Preset Setup and Recall

Preset function is to save the address information (such as PTZ pan/tilt, focus and etc) to the memory so that you can quickly adjust the dome and PTZ to the correct position. This series speed dome supports 200 presets.

1.2.6 Auto Scan

Camera scans back and forth regularly in a horizontal field. Here you need to set left and right limit and scan speed. You can set 5 scanning paths.

1.2.7 Auto Touring

Add addresses into a routine in a desired order and then set time and stop duration for each address. The dome will begin an auto touring between these addresses. You can set 8 touring paths.

1.2.8 Auto Pattern

Memorize dome operation such as pan, tilt, and zoom to repeat. Focus and iris are in auto mode during auto pattern. For each pattern, the time should be less than 60 seconds. You can set 5 pattern paths.

1.2.9 Privacy Masking

Privacy masking is a user-defined, four-sided area that can not be viewed by you. The masking area will move with pan and tilt functions and automatically adjust in size as the lens zooms. You can set 8 privacy masking zones (Depends on camera type).

1.2.10 Action on Alarm

This series speed dome support three alarm modes. There are 7 alarm inputs and 2 alarm outputs. Alarms can be individually programmed to initiated pattern, or go to an associated preset, scanning, touring when received. Dome will return to a previously programmed state after alarm acknowledgement or to its previous position before alarm.

1.2.11 Auto Flip

As long as you continue to hold the keyboard joystick in the down position, the dome rotates 180 degrees and repositions itself for uninterrupted viewing of any subjects that passes directly beneath the dome.

1.2.12 Self-diagnosis

There is a self diagnosis procedure when dome boots up.

- Tilt and vertical engine check
- Camera diagnostics
- Display dome information and diagnosis information such as address, protocol, baud rate, type.

1.2.13 Day/Night Mode (B/W & Color Mode)

Auto/manual switches in low illumination.

- Auto: camera will automatically adjust CCD light level.
- Manual: use menu or function keys to select day/night mode.

1.2.14 Auto Focus

Auto focus allows the lens to remain in focus during zoom-in, zoom-out and motion functions to get vivid image. You can use FAR or NEAR button to adjust focus manually.

1.2.15 Backlight Compensation

Balance the brightest and darkest sections of a scene to produce a more vivid picture.

1.2.16 Pan Tilt and Zoom

Supports zoom in and zoom out during tilt and pan movement.

In this period focus and iris are both in auto mode to get vivid image.

1.2.17 3D Intelligent Location

Working with DVR, just click part of the current scene will be displayed in the central window and automatically zooms. All of these allow you to trace precisely.

1.2.18 Idle Status

When there is no available order, you can use menu to set dome idle status after specified duration. The idle status includes turn to specified preset or go to scan, tour or pattern function.

1.2.19 Image Stabilizer/Flip

You can enable image stabilizer function and flip in the menu.

When there is vibration, this IS function can guarantee video stability and when flip, you can view video more clearly.

This function needs camera supported.

1.3 Specification

Power	AC 24V/3A (±20%) (Includes temperature control circuit)
Core Consumption	11W
Heater Consumption	30W
Decode Card	Built-in
Engine	stepper motor
Preset	200(in PELCO protocol)
Auto Tour	8
Auto Pattern	5
Auto Scan	5
Privacy Mask	Maximum 8 zones (according to camera core type)
Alarm Input/Output	7/2
Information	Time, address, dome title, dome coordinates, temperature, alarm and etc.
Lens	Adjust speed in accordance with lens
Auto Rotation	Tilt 92° auto rotates to pan 180 °
Auto Pan	0 ° -360° continuously
Manual Pan Motion Speed	0.1°—200°/S
Preset Maximum Speed	300°
Manual Tilt Motion	0.1°—120°/S
Manual Tilt Scan Section	0°—180°
Control Port	RS485 BUS
Baud Rate	1200/2400/4800/9600 (Optional)
PTZ Scan Accuracy	0.06 ± 0.015°
Signal Format	PAL/NTSC (Camera mode)
S/N Ratio	> 50dB
Effective Pixel	768(H)*494(V) 795(H)*596(V)
Horizontal Resolution	480TVL/540TVL
Fan and Heater	Fan works continuously and heater works automatically when temperature is below 5°C.
Humidity	<90%
Environment	-40°C—60°C (Outdoor)

Built-in Decode	<p>All digital design. All data are in the connection board. No data loss when power off occurs.</p> <ul style="list-style-type: none"> • Integrated design, high stability. • High speed dome max support 200 presets. Support 8 auto touring. Each touring max has 80 presets. • Medium and low speed dome has 32 presets. • 5 auto scan. • 5 auto pattern. Each pattern shall be less than 60s. • Built-in direction indicator. • RS485 BUS control. • Support max 8 privacy mask zones(Depends on the camera type) • 7 alarm inputs and 2 alarm outputs. • Built-in various adjustable protocols, baud rate. Support user self-defined communication protocol.
Built-in PTZ	<ul style="list-style-type: none"> • Fine stepper driver, stable performance, react quickly, precisely positioning. • Integrated design, tight structure. • Elegant mechanical driver device. Support 360 degrees continuous rotation, no monitor blind spot. • 0.1°/s rotation speed while maintain stable image. • 180 degrees tilt continuous monitor.
Built-in zoom lens, high sensitive, high resolution integrated digital process color camera.	<ul style="list-style-type: none"> • Auto focus • Auto backlight compensation • Auto brightness control • Auto white balance • Auto day/night switch (Auto B/W & color switch)
OSD	<ul style="list-style-type: none"> • Preset title display • View dome initial setup information • Modify camera parameter • Set preset • Set auto scan • Set 7 alarm inputs and 2 alarm outputs. • Set auto patter • Set auto day/night switch (Auto B/W & color switch) • Set privacy mask zones

2 Protocol, Baud Rate, Address setup

Before you operate, you need to set protocol, baud rate and address. Otherwise you can not control the product!

2.1 Protocol and Baud Rate Setup

Please configure the following settings before begin controlling dome:

- Protocol
- Baud rate
- Address

Note: Please reboot the speed dome to get all the setups activated!

Open the lower dome, the interface is shown as below. See Figure 2-1.

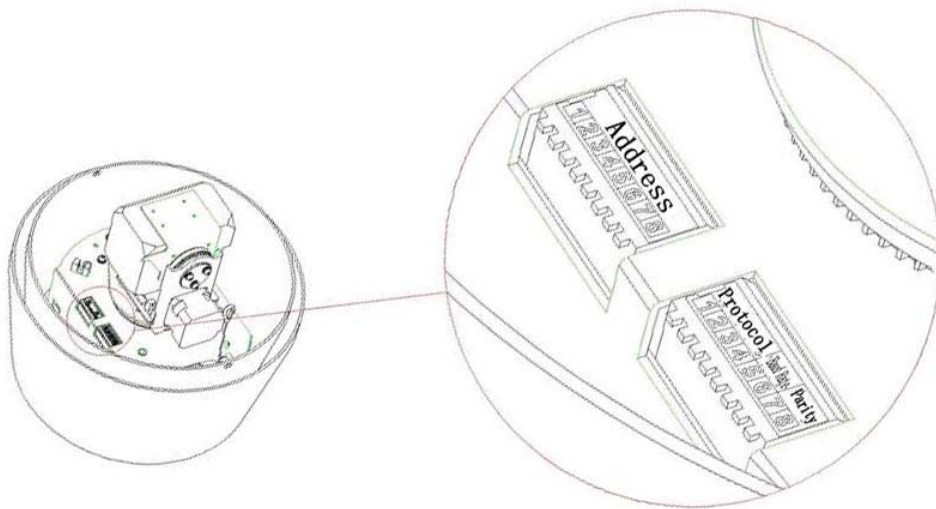

Figure 2-1

Please refer to the protocol sheets for detailed information.

Protocol				Baud rate		Parity	
1	2	3	4	5	6	7	8

1	2	3	4	Communication Protocol
OFF	OFF	OFF	OFF	DH-SD (Compatible with China industrial standard protocol)
ON	OFF	OFF	OFF	PELCO-D
OFF	ON	OFF	OFF	PELCO-P
X	X	X	X	Reserved

Please refer to the baud rate sheet for detailed information.

5	6	Baud Rate
OFF	OFF	9600bps
ON	OFF	4800bps
OFF	ON	2400bps
ON	ON	1200bps

Please refer to the parity setup sheet for detailed information.

7	8	Parity
OFF	OFF	NONE
ON	OFF	EVEN
OFF	ON	ODD
ON	ON	NONE

2.2 Set address dial switch

The encode mode adopts binary system. 1 to 8 is valid bit. The highest address bit is 255. You can refer to the following sheet for more information.

Address	1	2	3	4	5	6	7	8
1	OFF	OFF	OFF	OFF	OFF	OFF	OFF	OFF
1	ON	OFF	OFF	OFF	OFF	OFF	OFF	OFF
2	OFF	ON	OFF	OFF	OFF	OFF	OFF	OFF
3	ON	ON	OFF	OFF	OFF	OFF	OFF	OFF
4	OFF	OFF	ON	OFF	OFF	OFF	OFF	OFF
5	ON	OFF	ON	OFF	OFF	OFF	OFF	OFF
6	OFF	ON	ON	OFF	OFF	OFF	OFF	OFF
7	ON	ON	ON	OFF	OFF	OFF	OFF	OFF
8	OFF	OFF	OFF	ON	OFF	OFF	OFF	OFF
.....							
254	OFF	ON	ON	ON	ON	ON	ON	ON
255	ON	ON	ON	ON	ON	ON	ON	ON

3 Cable Connection

3.1 RS485 and Power Cable Connection

There are three cable groups: power cable, RS 485 and video cable. Draw out the cables from the dome to connect with main control devices (such as monitor, control keyboard, DVR and etc.) and power adapter. See Figure 3-1 and Figure 3-2.

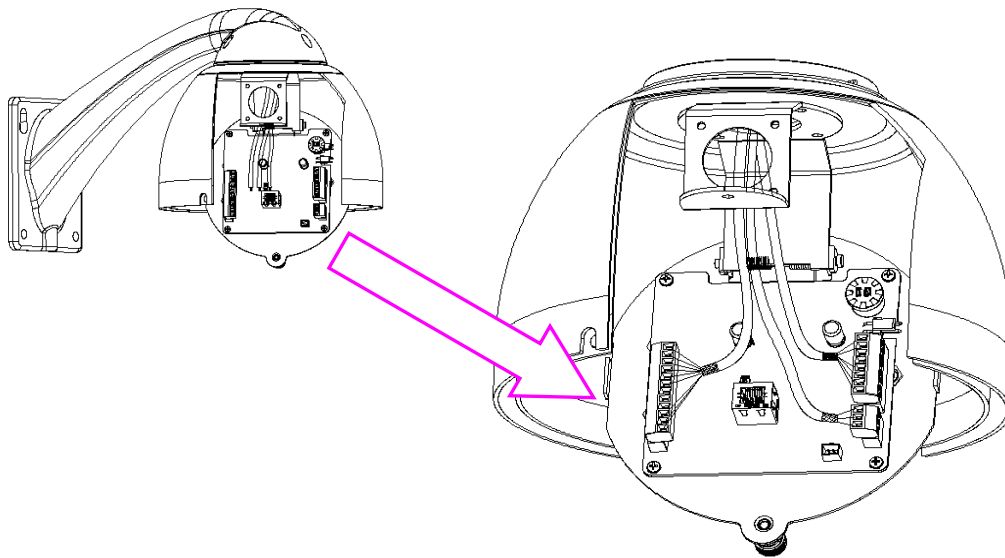

Figure 3-1

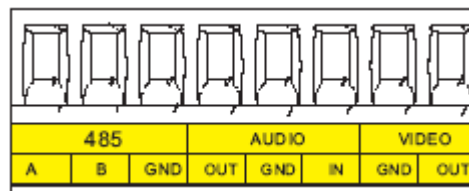

Figure 3-2

Name		Function
485	A	485-A. It is to control dome built-in PTZ.
	B	485-B. It is to control dome built-in PTZ.
	GND	Ground.
AUDIO	OUT	Reserved audio port. Audio output port.
	GND	Reserved audio port. Ground port audio.
	IN	Reserved audio port. Audio connection port.
VIDEO	GND	Ground port.
	OUT	Video output port.

Power port connection interface is shown as in Figure 3-3.

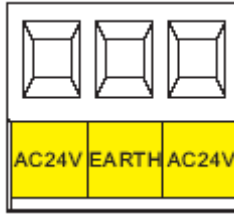

Figure 3-3

Name	Function
AC24V	24V power port. Connect to the power cable.
EARTH	Ground port.
AC24V	24V power port. Connect to power cable.

Extension RS 485 port is shown as in Figure 3-4.

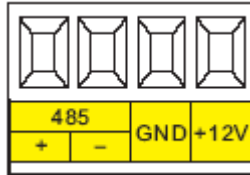

Figure 3-4

Name	Function	
485	+	Extension peripheral 485 port. Such as control temperature, humidity sensor.
485	-	Extension peripheral 485 port. Such as control temperature, humidity sensor.
GND		Ground port.
+12V		External device power port. Provide power the Peripheral.

3.2 Alarm Cable Connection

Open the dome cover and take PTZ chip core out. Turn the core upside down; you can see the alarm port. See Figure 3-5.

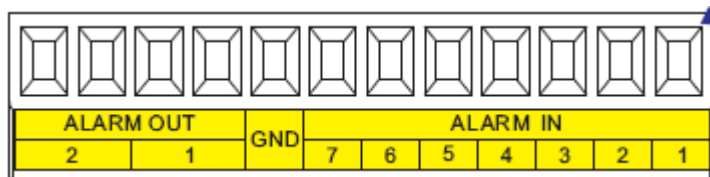

Figure 3-5

Name	Function
Alarm out: 1-2	<ul style="list-style-type: none"> • Two alarm output channels. When there is an alarm from current channel, system activates relay or not. • Alarm output relay default setup is NO. You can use the jump-cap near the power board relay to set. • NO: Normal open alarm output. • NC: Normal close alarm output.
GND	Alarm input ground end.
Alarm in: 1-7	<ul style="list-style-type: none"> • Seven alarm input channels. It is to receive relay signal from the external alarm source. You can go to dome menu to activate specified preset or patter. • When the activation mode is NO (normal open), dome alarms when there is low voltage. High voltage will not activate the alarm. • When the activation mode is NC (normal close), dome alarms when there is high voltage. Low voltage will not activate the alarm. <p>Note:</p> <ul style="list-style-type: none"> ● Dome alarm input message is ground mode. ● Dome alarm input signal are two modes: normal open and normal close.

3.2.1 System Layout

3.2.1.1 BUS connection

Please refer to Figure 3-6 and Figure 3-7 for BUS cable connection.

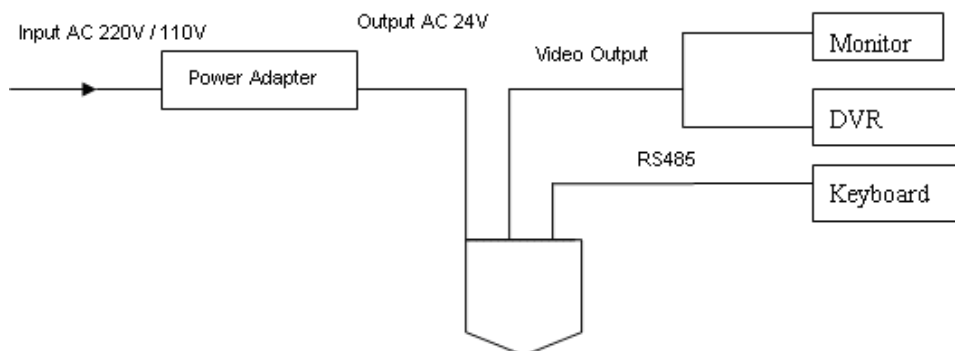

Figure 3-6

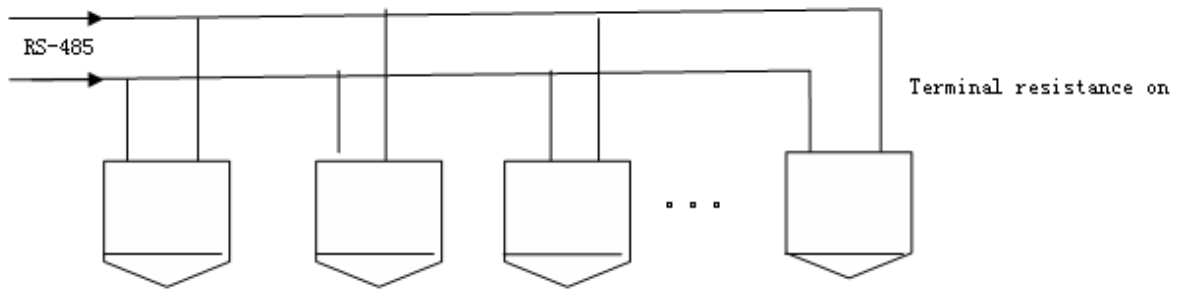

Figure 3-7

Note:

Please use shielded twisted pair. The shielded layer shall connect to GND firmly; otherwise it may affect communication or video work.

3.2.1.2 Star Connection

Please refer to Figure 3-8 for start connection information.

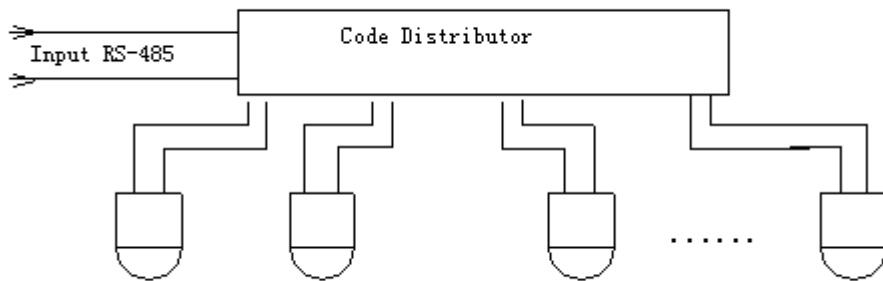

Figure 3-8

3.2.2 Alarm Connection

Please refer to Figure 3-9 for alarm connection information.

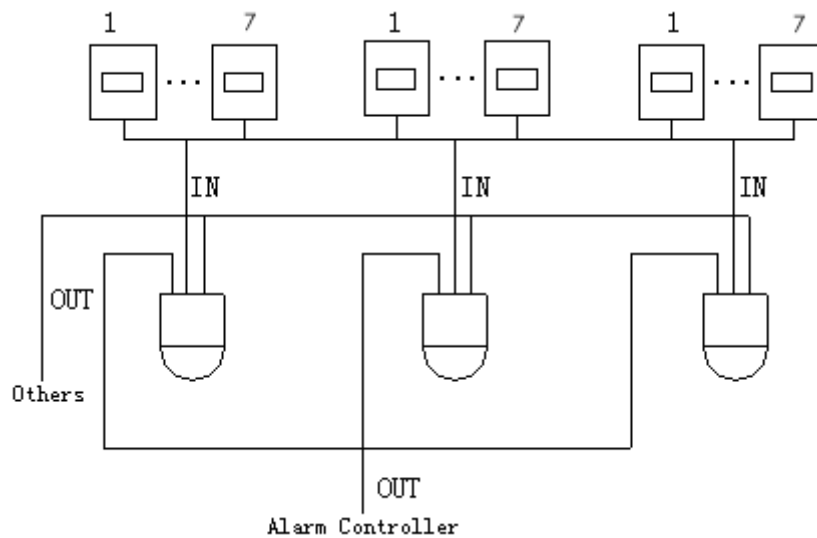

Figure 3-9

3.2.3 Keyboard Connection

This series dome supports keyboard operation. You can use keyboard to control the dome and PTZ. The display and control can work simultaneously. One keyboard can control maximum 255 speed domes. Please refer to Figure 3-10.

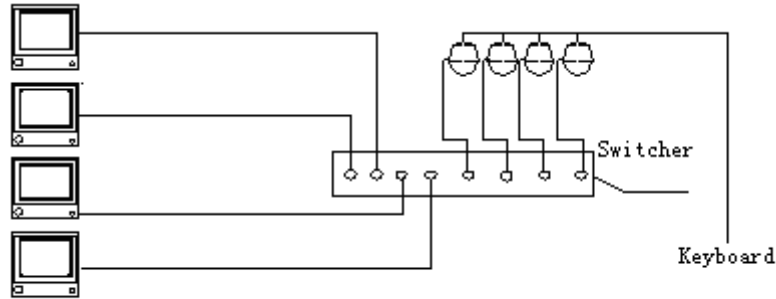

Figure 3-10

Speed dome protocol is open and supports multiple popular system platforms in today's market. Please contact us freely if some matrix systems do not support dome camera communication protocol. The most direct and easy way is to use current system to process video signal and add some control keyboards to control speed dome. See Figure 3-11.

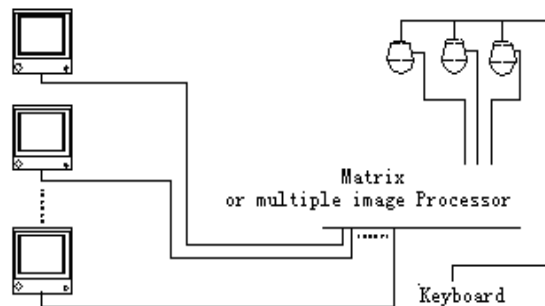

Figure 3-11

4 Menu

4.1 Screen Menu Index

Note:

ERR means current setup is invalid.

... means there is submenu.

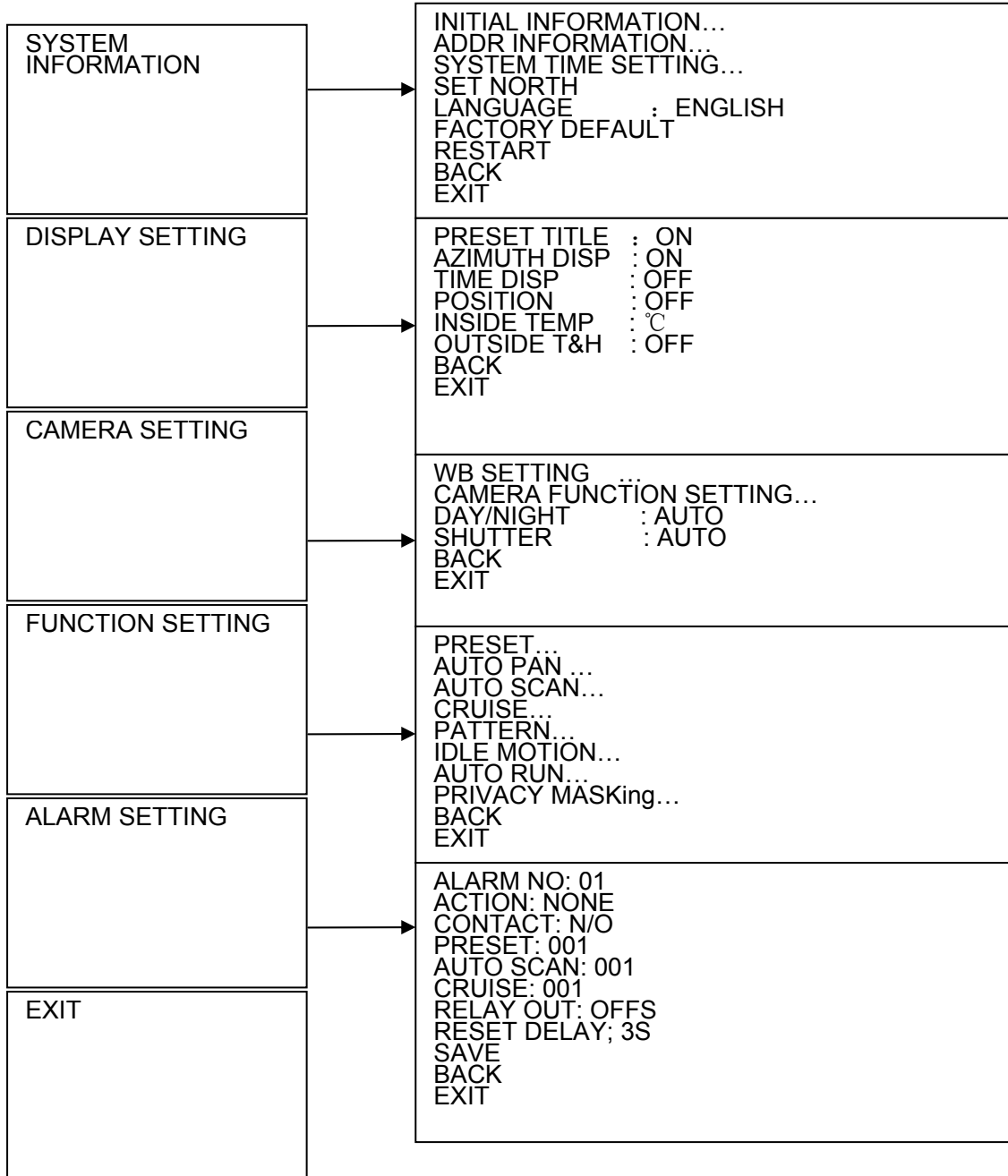

The above diagram illustrates the overall structure of the Setup Menu.

Note:

If you are using keyboard or matrix to control dome, please make sure the control information setup (such as address, baud rate parity and protocol) are the same with that of the dome.

Please make sure all the cable connections are right.

4.2 System Information

ADDR	: 001-H
BAUD RATE	: 9600
PARITY	: NONE
PROTOCOL	: PELCO-P
MODEL	: SD66xx-H
TEMP	: 032°C
SOFTWARE	: V1.02
BACK	
EXIT	

After installation, please connect speed dome to power. The system goes on a self-diagnosis, and then it pops up the above interface to show the system information. If there is anything wrong during the self-diagnosis, system pops up error code. The above interface disappears after speed dome receive the first command (or there is no valid command for four minutes.)

- ADDR: Dome address information. For example, 001-H, 1 is the address number, -H is hard address mode. -S is software address mode.
- Baud rate: Dome communication baud rate.
- Parity: Communication parity bit format.
- Protocol: Current communication protocol.
- Model: Dome type.
- Temperature: Current dome internal temperature.
- Software: Dome software version.

Note: This screen is for reference only.

4.3 Main Menu

SYSTEM INFORMATION
DISPLAY SETTING
CAMERA SETTING
FUNCTION SETTING
ALARM SETTING
EXIT

- SYSTEM INFORMATION : Dome self-diagnosis information, address information, system time setup, set north direction, language, factory default setup, reboot, temperature and so on.
- DISPLAY INFORMATION: Display dome preset title, azimuth display, time, direction, dome internal temperature, dome external temperature.
- CAMERA PARAMETERS : Display dome white balance setup, camera function setup, day/night setup, shutter setup.
- FUNCTION SETTING : Set preset, auto pan, auto scan, cruise, pattern, idle motion, auto run and privacy mask function.

- ALARM SETTING : Set dome alarm number, action, contact, preset, auto scan, cruise, replay out, reset delay, save setup and etc.
- EXIT : Log out the system menu.

4.4 Menu Operation

In menu, you can use the following three functions to configure or leave system menu.

- In main menu, use left/right key to select the desired item until there is an icon ▷ before the item name. Please click confirm button to go to the sub menu or use left/right key to configure setup.
- Use left/right key to back button and then click confirm button to go back to the previous menu.
- Use left-right key to exit button and then click confirm button to log out system menu.

4.4.1 Dome System Information

INITIAL INFORMATION*** ADDR INFORMATION*** SYSTEM TIME SETTING*** SET NORTH LANGUAGE FACTORY DEFAULT RESTART BACK EXIT
--

- INITIAL INFORMATION: Move the cursor to INITIAL INFORMATION and then click confirm button to go to the third submenu.
- ADDR INFORMATION: Move the cursor to SITE INFORMATION and then click confirm button to go to the third submenu.
- SYSTEM TIME SETTING: Move the cursor to SYSTEM TIME SETTING and then click confirm button to go to the third submenu.
- SET NORTH DIRECTION: Set dome benchmark direction so that you can know the angel between the benchmark and then current location. Please move the cursor to the option and then click confirm button until you see O.K. Now you have set north direction.
- LANGUAGE: The dome menu language. There are several languages for you to select. Use left/right button to set and then click confirm button to save current option.
- FACTORY DEFAULT: Restore dome factory default setup.
- RESTART: Reboot the system.
- BACK: Go back to the previous menu.
- EXIT: Log out system menu.

4.4.1.1 Initialization information

```

ADDR          : 001-H
BAUD RATE    : 9600
PARITY       : NONE
PROTOCOL     : PELCO-D
MODEL        : SD66xx-H
TEMP         : 032°C
SOFTWARE     : v1.02
BACK
EXIT

```

Move the cursor to INITIAL INFORMATION and then click confirm button, you can see the above interface.

Here you can view some basic information.

4.4.1.2 Address Information

```

ADDR TYPE    : HARD
ADDR-HARD    : 001
ADDR-SOFT    : 001
BACK
EXIT

```

Move the cursor to SITE INFORMATION and then click confirm button.

- ADDR TYPE: Please use the left/right key to select address types. There are two options: soft and hard.
- ADDR-HARD: It is an address you set in the dial switch. You can not modify it through software.
- ADDR-SOFT: You can set address via software. It is to say, you can use menu to modify dome address. The value ranges from 1 to 255.
- BACK: Go back to the previous menu.
- EXIT: Log out system menu.

4.4.1.3 System Time Setting

```

YEAR        : 2008
MONTH:      : 001
DATE:       : 017
HOUR :      : 013
MINU:       : 052
SAVE
BACK
EXIT

```

Move the cursor to SYSTEM TIME SETING and then click confirm button, you can go to the third submenu. Please use left/right key to select. After completed setup, please click save button to save current setup.

4.4.2 Display Setup

```

PRESET TITLE : ON
AZIMUTH DISP : ON
TIME DISP    : OFF
POSITION     : OFF
INSIDE TEMP  : °C (°C/F/OFF)
OUTSIDE T&H  : OFF
BACK
EXIT

```

Move the cursor to DISPLAY SETUP and then click confirm button, you can go to the third submenu. Please use left/right key to select. After completed setup, please click save button to save current setup.

- PRESET TITLE: Display dome preset title or not. Please use left/right key to select. You can go to Function Setup->Preset section to set corresponding preset value and preset title.
- AZIMUTH DISP: Display dome current coordinates or not. Please use left/right key to select.
- TIME DISP: Display dome system time or not. Please use left/right key to select.
- POSITION: Display the angel between the benchmark and then current location. Please use left/right key to select.
- INSIDE TEMPERATURE: Display dome internal temperature or not. There are three options: °C, F,off. Please use left/right key to select.
- OUTSIDE TEMPERATURE AND HUMIDITY: Display dome external temperature and humidity. There are three options: °C, F,off. Please use left/right key to select.
- BACK: Go back to the previous menu.
- EXIT: Log out system menu.

4.4.3 Camera Setup

```
WB SETTING...  
CAMERA FUNCTION SETTING...  
DAY/NIGHT      : AUTO  
SHUTTER        : AUTO  
BACK  
EXIT
```

Move the cursor to CAMERA SETUP and then click confirm button, you can go to the submenu.

- WHITE BALANCE SETUP: Move the cursor to current option and then click confirm button, you can go to the third menu.
- CAMERA FUCNTION SETUP: Move the cursor to current option and then click confirm button, you can go to the third menu.
- DAY/NIGHT: Set day/night mode. There are three options: auto/manual/off. Please use left/right key to select.
- SHUTTER: Here you can set camera shutter speed. There are several options such as AUTO , 1/3 ~ 1/100000s. You need to set aperture mode as manual if you want to enable shutter setup.
- BACK: Go back to previous menu.
- EXIT: Log out system menu.

4.4.3.1 White Balance Setup

```
WB MODE  : AUTO  
R GAIN   : 001  
B GAIN   : 001  
BACK  
EXIT
```

Move the cursor to WHITE BALANCE MODE and then click confirm button, you can go to the submenu.

- WHITE BALANCE MODE: Set white balance adjustment mode. There are two modes: auto/manual. Please use left/right key to select.
- R GAIN : Before you set R GAIN option, please set white balance mode as manual. The value ranges from 0 to 254. Please use left/right key to select.
- B GAIN : Before you set B GAIN option, please set white balance mode as manual. The value ranges from 0 to 254. Please use left/right key to select.
- BACK: Go back to previous menu.
- EXIT: Log out system menu.

4.4.3.2 Camera Function Setting

DIGITAL ZOOM	: OFF
MANUAL FOCUS	: OFF
MANUAL IRIS	: OFF
BLC	: OFF
PICTURE FLIP	: OFF
STABLE FUNCTION	: OFF
FREEZE FUNCTION	: OFF
WDR ENABLE	: OFF
BACK	
EXIT	

Move the cursor to CAMERA FUNCTION SETTING and then click confirm button.

- DIGITAL ZOOM : There are two digital zoom settings: auto or manual. Please use left/right key to select.
- MANUAL FOCUS: There are two options: enable or disable. Please use left/right key to select.
- MANUAL IRIS: There are two options: enable or disable. Please use left/right key to select.
- BLC: Set camera brightness. Please use left/right key to select.
- PICTURE FLIP: You can turn the image rotation 180 degrees. Please use left/right key to select.
- STABLE FUNCTION: Here you can enable image stabilize function. Please note this function needs camera supported.
- FREEZE FUNCTION: This function allows system from on preset image to another image directly.
- WDR ENABLE: Wide dynamic region function allows system to adjust image brightness when the environment is too bright or too dark.
- BACK: Go back to previous menu.
- EXIT: Log out system menu.

4.4.4 Function Setting

```

PRESET ...
AUTO PAN...
AUTO SCAN...
CRUISE...
PATTERN...
IDLE MOTION...
AUTO RUN...
PRIVACY MASKING...
BACK
EXIT

```

Please go back to main menu and move the cursor to FUNCTION SETTING, click confirm button.

You can see the above interface.

4.4.4.1 Preset Setup

```

PRESET NO : 001
TITLE   : PRESET001
SETTING
CALL
BACK
EXIT

```

Move the cursor to PRESET button and then click confirm button to go to set interface.

- PRESET NO: Please use left/right key to modify preset number. The value ranges from 1 to 80.
- TITLE : Title text is the label used for you to identify the camera. System will automatically name a title for the camera.
- SETTING: Please input preset number first and then select the monitor zone. Please move the cursor to setting and click confirm button. The system will pop up a message: PRESET: ***. Here *** means preset number. And the SETTING column pops up an OK. Now you successfully added a preset. Please note, you need to enable display preset title function first (Main menu->display setting->preset title).
Repeat the above procedures to set more presets.
- CALL: Here is to recall preset. Move the cursor to PRESET NO and then input corresponding preset value. Then move the cursor to CALL and then click confirm button to go to a preset.
- BACK: Go back to previous menu.
- EXIT: Log out system menu.

For PELCO protocol user, please refer to the following special functions:

- **Call preset:** Call preset 28 or preset 95 to go to dome menu. Call preset 29 or preset 9 to go to scan. Call preset 24 or preset 81 to go to pattern. Call preset 25 or preset 82 to go to cruise(tour). Call preset 30 or preset 96 to stop scan or

pattern. Call preset 31 or preset 83 to begin rotation. Call preset 33 to enable PTZ 180 degrees rotation. Call preset 34 to set dome position as 0.

- **Set preset:** Set preset 26 or 92 to set scan left limit. Set preset 27 or 93 to set scan right limit. Set preset 22 or 70 to begin record. Set preset 23 or 80 to stop record.

4.4.4.2 Auto Pan

```
PAN SPEED : 160
RUN
STOP
BACK
EXIT
```

Move the cursor to ROTATION button and then click confirm button to go to setup interface.

- PAN SPEED: Set dome rotation speed. The Value ranges from 1 to 255. Please use left/right key to select.
- RUN: Move the cursor to call item and then click confirm button. The dome begins 360 degrees continuous rotation.
- STOP: Highlight stop item and then click confirm button. The dome stops rotation.
- BACK: Go back to previous menu.
- EXIT: Log out system menu.

4.4.4.3 Auto Scan

```
AUTO SCAN NO : 001
SET LEFT LIMIT
SET RIGHT LIMIT
SCAN SPEED : 160
RUN
STOP
BACK
EXIT
```

Move the cursor to AUTO SCAN button and then click confirm button.

- SCAN NO : Here is to set auto scan number. The value ranges from 1 to 5. Please use left/right key to configure.
- SET LEFT LIMIT : Here is to set camera left address.
- SET RIGHT LIMIT : Here is to set camera right address.
- SCAN SPEED: The value ranges from 1 to 255. Please use left/right key to configure.
- RUN: Please input auto scan number first, and then please move the cursor to RUN and click confirm button to activate auto scan function.
- STOP: Here is to terminate auto scan function.
- BACK: Go back to previous menu.
- EXIT: Log out system menu.

4.4.4.4 Cruise (Touring)

CRUISE NO:	: 001
DWELL	: 005
PRESET NO	: 001
ADD PRESET	
REMOVE PRESET	
DELETE CRUISE	
RUN	
STOP	
BACK	
EXIT	

Move the cursor to highlight AUTO TOURING item and then click confirm button to go to set interface.

- CRUISE NO : Here is to set tour number. The value ranges from 1 to 8. Please use left/right key to configure.
- DWELL: Here is to set dwell time. The value ranges from 3s to 255s. Please use left/right key to configure.
- PRESET NO : Here is to show preset number. There are maximum 80 presets in one tour. Please use left/right key to configure.
- ADD PRESET: Here is for you to add a preset. Input preset number in PRESET NO and then move the cursor to ADD PRESET, please click confirm button to add one preset into the cruise.
- REMOVE PRESET : Here is to delete a preset. Input preset number in PRESET NO and then move the cursor to REMOVE PRESET, please click confirm button to remove one preset from the tour.
- DELETE CRUISE : Here is to delete a cruise. Input cruise number in CRUISE NO and then move the cursor to DELETE cruise, click confirm button to delete.
- CALL: Here is to activate cruise. Input touring number in touring NO and highlight CALL, click confirm button to activate touring.
- STOP: Here is to terminate touring.
- BACK: Go back to previous menu.
- EXIT: Log out system menu.

4.4.4.5 Pattern

PATTERN NO: 001
PROGRAM START
PROGRAM STOP
RUN
STOP
BACK
EXIT

Pattern function can memory PTZ operation and camera focus zoom in and zoom out.

From the start position, dome begins auto movement repeatedly.
The dome supports maximum 5 patterns and for each pattern shall be less than 60 seconds.

Move the cursor to PATTERN and click confirm button.

- PATTERN NO : Here is to set pattern number. The value ranges from 1 to 5.
Please click left/right key to configure.
- PROGRAM START: Here is to memorize pattern starting point. An icon OK pops up in screen to prompt you system begins memory pattern..
- PROGRAM STOP : Here is to set pattern stop point. After all the movement, move the cursor to PROGRAM STOP and then click confirm button. Now you have set one pattern. System pops up an icon OK to prompt you system has memories one pattern.
- RUN : Here is to activate pattern. Input pattern number, move the cursor to RUN and click confirm button, system begins running pattern.
- STOP: Here is to stop current pattern. Input pattern number, move the cursor to STOP and click confirm button. System stops current pattern.
- BACK: Go back to previous menu.
- EXIT: Log out system menu.

Note:

- The dwell time between two orders should be less than one minute, otherwise system will set to default value as one minute.
- After click PROGRAM STOP, do not click CALL button before icon “●” disappears completely.
- Any manual operation during the pattern procedure will terminate current dome pattern operation.

4.4.4.6 Auto Run

AUTO RUN	: OFF
START TIME	: 00H
END TIME	: 05H
RUN ACTION	: PRESET
PRESET NO	: 001
AUTO SCAN NO	: 001
CRUISE NO	: 001
PATTERN NO	: 001
SAVE	
BACK	
EXIT	

This function allows speed dome to work during the specified period.

- AUTO RUN FUNCTION : There are two modes ON/OFF. Please use left/right key to set.
- START TIME: You can select auto run start time.
- END TIME: You can select auto run end time.
- RUN ACTION: There are several functions you can select: NONE/PRESET/SCAN/CRUISE/PATTERN. Please use left/right key to select.
- PRESET NO: Here is for you to set preset number. The value ranges from 1 to 80.
- AUTO SCAN : The value ranges from 1 to 5. Please use left/right key to select.
- CRUISE NO: The value ranges from 1 to 8. Please use left/right key to select.
- PATTERN NO: The value ranges from 1 to 5. Please use left/right key to select.
- SAVE: Move the cursor to SAVE button and then click confirm button to save current setup.
- BACK: Go back to previous menu.
- EXIT: Log out system menu.

4.4.4.7 Privacy Masking (Window blank)

PRIVACY MASKING NO: 001
RESIZE : ↑
ACTIVATE : OFF
SAVE
DELETE
BACK
EXIT

Move the cursor to PRIVACY ZONE and click confirm button, system goes to privacy mask setup interface.

For SONY series cameras

There are maximum 8 privacy mask zones in 360 degrees .The tilt angle ranges from 0 to 70 degrees.

For HITACHI series cameras

There are maximum 8 window blanks in 360 degrees. System supports two privacy zones in one screen (Tilt angle ranges from 0 to 45 degrees.)

Note:

- For security reasons, please set privacy zone a little bit larger than the privacy object size.
- Each time, after modifications you need to move the cursor to SAVE button and then click confirm button to get all setup activated. Otherwise, privacy zone may not move correspondingly with the object.

Please enter privacy zone menu, now all the privacy zones are closed.

Move the cursor to PRIVACY ZONE, please use left/right key to set different privacy zones.

For example, shift to 001 section and then move the cursor to ACTIVATE.

Secondly, click left and right key to ON mode. Now there is a privacy zone in the screen centre.

Thirdly, use PTZ to move camera so that privacy object fit well with screen centre.

Fourthly, move the cursor to RESIZE and then click left and right key to adjust privacy zone direction and size.

Fifthly, move the cursor to SAVE and then click confirm button to exit.

- PRIVACY ZONE NO : Here is to set privacy mask zones. Please use left/right key to configure. The value ranges from 1 to 24.
- RESIZE : Continue pressing direction button to widen or narrow zone size.
- ACTIVATE: There are two settings: on and off. When activate function is on, the window blank function will be activated and displays in the screen. When activate function is off, the privacy mask function will be closed and the blank will not displayed in the screen.
- SAVE : Here is to save user setup.
- DELETE: Here is to delete setup and restore default setting.
- BACK: Go back to previous menu.
- EXIT: Log out system menu.

4.4.4.8 Idle Motion

IDLE FUNC	: OFF
IDLE TIME	: 010MIN
IDLE ACTION	: PRESET
PRESET NO	: 001
AUTO SCAN NO	: 001
CRUISE NO	: 001
PATTERN NO	: 001
SAVE	
BACK	
EXIT	

When there is no available order for specified time, dome automatically goes on the previous set functions.

- IDLE FUNCTION : There are two modes ON/OFF. Please use left/right key to set.
- IDLE TIME: System idle period. The value ranges from 1 to 720 minutes. Please use left/right key to select.
- IDLE ACTION: There are several functions you can select: NONE/PRESET/SCAN/TOURING/PATTERN. Please use left/right key to select.
- PRESET NO: Here is for you to set preset number. The value ranges from 1 to 80. System goes to specified preset when idle status is on.

- AUTO SCAN NO: The value ranges from 1 to 5. Please use left/right key to select. System begins specified scan when idle status is on.
- CRUISE NO: The value ranges from 1 to 8. Please use left/right key to select. System begins specified touring when idle status is on.
- PATTERN NO: The value ranges from 1 to 5. Please use left/right key to select. System begins specified pattern when idle status is on.
- SAVE: Move the cursor to SAVE and click confirm button to save current setup.
- BACK: Go back to previous menu.
- EXIT: Log out system menu.

4.4.5 Alarm Setup

ALARM NO	: 01
ACTION	: NONE
CONTACT	: N/O
PRESET NO	: 001
AUTO SCAN	: 001
CRUISE	: 001
RELAY OUT	: OFFS
RESET DELAY	: 3S
SAVE	
BACK	
EXIT	

Move the cursor to highlight ALARM SETTING button and then click confirm button.

- ALARM NO: Here is to set alarm input. Alarm input value ranges from 1 to 7. Please use left/right key to select.
- ACTION: Action on alarm function. It includes NONE/PRESET/AUTO SCAN/TOURING functions. Please use left/right key to select.
- CONTACT : There are two alarm signal mode: normal open (N/O) and normal closed (N/C). Please use left/right key to select.
- PRESET NO : Please use left/right key to select. The camera will turn to the specified preset to monitor after alarm occurs.
- AUTO SCAN : Please use left/right key to select. The camera will begin auto scan after alarm occurs.
- CRUISE : Please use left/right key to select. The camera will begin auto cruise when alarm occurs.
- RELAY OUT: Here is to set relay alarm mode and reset time. There are several options: off/1→5S/2→5S/1&2→5S.
 - ✧ 1→5S: 1 means the first relay output.5S means the relay will reset in five seconds after alarm occurs.
 - ✧ 1&2→5S: 1&2 means the first relay and the second relay work at the same time.

- **RESET DELAY:** Here is for you to set alarm reset time. You can use left/right key to select: 3 seconds/10seconds/30 seconds/60 seconds /120seconds. The dome will go back to previous setup after alarm acknowledgement.
- **SAVE:** Move the cursor to SAVE and then click confirm button to save current setup.
- **BACK:** Go back to previous menu.
- **EXIT:** Log out system menu.

4.5 Dome Abnormal Phenomenon Operation

4.5.1 Restore to Factory Default Setup

From main menu-> SYSTEM INFORMATION, move cursor to FACTORY DEFAULT and click confirm button. Dome will reboot and all the setup restore to factory default setup.

4.5.2 PTZ Movement is not smooth

From menu to SYSTEM INFORMATION, move cursor to RESTART and click confirm button. This reboot will not modify all activated setup (such as preset, tour and pattern)

5 FAQ

5.1 Daily Maintenance

Please clean dome cover regularly to get vivid image.
 Handle the cover with care. Use water to wash. Don't use cloth to clean.
 Use mild detergent to clean if there is too much dust.

Note:

The sweat from your hand may erode plating surface, your nail may scrape dome cover result in blur image.

5.2 Problems and Solutions

SYMPTOM	CAUSE	SOLUTION
No self-diagnosis, no video signal when I connect dome to power.	Red LED is not on. <ul style="list-style-type: none"> ● 24V AC does not apply to the power. Or connection is too loose. ● Power off or Transformer problem. 	<ul style="list-style-type: none"> ● Check 24V AC power is connected or properly earthed. ● Check power supply condition or check 24V transformer.
	Red LED light is on <ul style="list-style-type: none"> ● 24V AC power is low ● Something wrong with power socket. 	<ul style="list-style-type: none"> ● Use multimeter to check dome load. ● Please contact retailer to replace power socket.
No self diagnosis. There is a noise	Power supply is inadequate.	Replace power socket.
	Mechanical malfunction.	Need electrical engineer help.
Self diagnosis is ok. No video signal	Power connection is too loose.	connect tightly
	Check the circuit connection.	Connect again
	Video switch connection is wrong or improper operation.	Please refer to user's manual for cable connection information.
Self diagnosis is o.k. but I can not operate the dome.	Control circuit is not properly connected	check control cable connection.
	Dome address, protocol or baud rate setup is not right.	Please refer to user's manual for detailed information.
Video signal loss occurs in high speed rotation.	Power supply is not sufficient	Replace power socket.
Video signal is not successive	Circuit connection is too loose.	Connect tightly.
	Video switch or power problem	Need electrical engineer help.
Video is not clear.	Focus is in manual mode.	Control manually.
	Dome cover is dirty.	Wash dome cover
During camera switch, there is a tilt movement in the monitor.	Camera power is not in the same Phase.	When several domes are connected to one transformer, please connect the transformer output cable to the domes' same side.

6 Appendix I Thunder Proof and Surge Protection

This series speed dome adopts TVS lightning protection technology. It can effectively prevent damages from various pulse signals below 1500W, such as sudden lighting and surge. While maintaining your local electrical safety code, you still need to take necessary precaution measures when installing the speed dome in the outdoor environment.

- The distance between the signal transmission cable and high-voltage device (or high-voltage cable) shall be at least 50 meters.
- Outdoor cable layout shall go under the penthouse if possible.
- For vast land, please use sealing steel tube under the land to implement cable layout and connects one point to the earth. Open floor cable layout is forbidden.
- In area of strong thunderstorm hit or near high sensitive voltage (such as near high-voltage transformer substation), you need to install additional high-power thunder protection device or lightning rod.
- The thunder protection and earth of the outdoor device and cable shall be considered in the building whole thunder protection and conform to your local national or industry standard.
- System shall adopt equal-potential wiring. The earth device shall meet anti-jamming and at the same time conforms to your local electrical safety code. The earth device shall not short circuit to N (neutral) line of high voltage power grid or mixed with other wires. When connect the system to the earth alone, the earth resistance shall not be more than $4\ \Omega$ and earth cable cross-sectional area shall below $25\ \text{mm}^2$. See Figure 6-1.

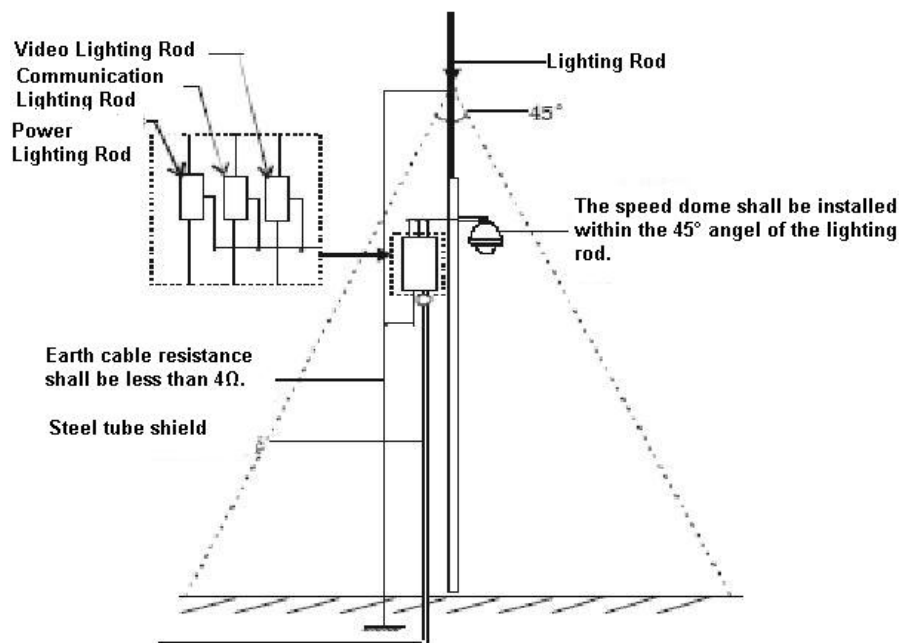

Figure 6-1

7 Appendix II About RS485 Bus

7.1 RS485 Bus Main Feature

RS485 is semi duplex communication cable of impedance $120\ \Omega$. Its max load amount is 32 effective loads (including main control device and devices to be charged).

7.2 RS485 Bus Transmission Distance

When we take 0.56mm (24AWG) twisted-pair as communication cable, the max transmission distance (theoretically) are listed below (according to different baud rates).

Baud Rate	Max Distance
2400 BPS	1800M
4800 BPS	1200M
9600 BPS	800M

In the following situations, the max transmission distance shall become shorter accordingly:

- The communication cable is a little bit thin;
- The surrounding environment has strong electromagnetic interference;
- There are too much devices connected to the RS485 bus;

And vice versa, the max transmission distance shall become longer.

7.3 Connection Methods and Terminal Resistance

RS485 bus requires all devices use the following connection methods. Both terminals shall have $120\ \Omega$ resistance. See Figure 7-1.

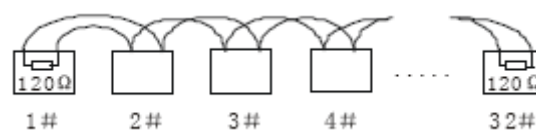

Figure 7-1

Or you can refer to for the simplified way as in Figure 7-2. But the distance between “D” shall not exceed 7M.

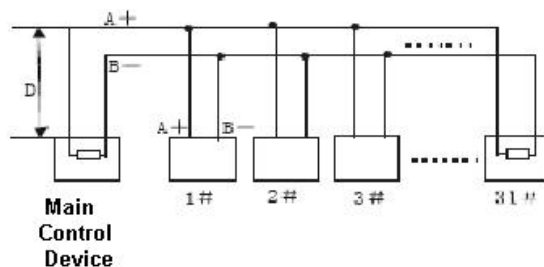

Figure 7-2

About device terminal 120 Ω connection

J2	1-2	2-3
120 Ω	ON	OFF

There are 120 Ω device terminal resistance in power socket. There are two connection ways.

The first one is shown as in Figure 7-3. It is the factory default connection method. Now the jumper caps (connection board) are connected to the second and third socket, the 120 Ω has not connected.

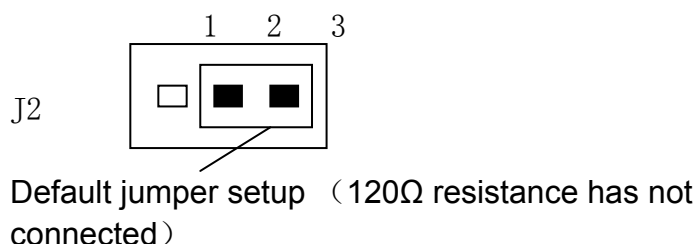

Figure 7-3

If you want to connect to the 120 Ω resistance, you can remove the jumper caps from the second and the third socket and then insert them to the first and second socket respectively. See Figure 7-4. Now you has connected to the 120 Ω resistance.

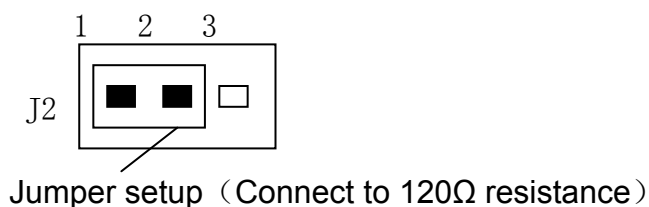

Figure 7-4

7.4 The Problem in Practical Use

In practical usage, we usually adopt star type connection. The terminal resistance shall connect to the furthest two devices (Such as device 1# and device 15# in Figure 7-5). But this connection way does not conform to RS485 Bus standard. When the distances between devices are too long, the signal reflection occurs and

anti-jamming decreases, thus the signal reliability becomes very low. You can see speed dome is not under control or speed dome is running automatically and can not stop.

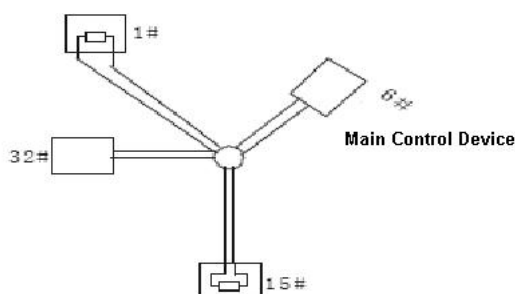

Figure 7-5

In this situation, we recommend RS485 distributor. This device can turn star type connection into the connection that conforms to RS485 bus industry standard, which can avoid the above mentioned problems and enhance communication reliability. See Figure 7-6.

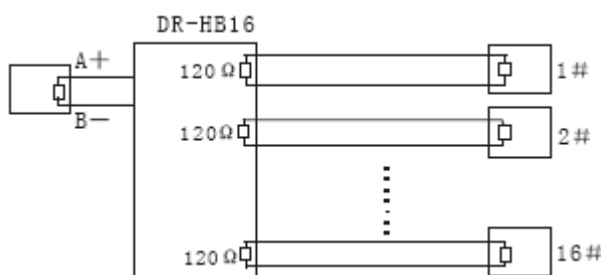

Figure 7-6

7.5 RS485 Bus FAQ

Phenomenon	Possible Reasons	Solution
Speed dome can run self-diagnosis but I can not control it.	<ul style="list-style-type: none"> ● Host address(baud rate) and speed dome address(baud rate) are not match; ● Positive and negative end of RS485 Bus are misconnected; ● Connection cable is loose; ● RS485 Bus connection are cut off; 	<ul style="list-style-type: none"> ● Modify host or speed dome setup ; ● Switch RS485 positive end and negative end; ● Fix connection cable firmly; ● Replace RS485 Bus.
I can control the speed dome but is not smooth	<ul style="list-style-type: none"> ● RS485 Bus connection are not good; ● One RS485 bus is off; ● The distance between host and speed dome is too far; ● Parallel connected too much speed domes. 	<ul style="list-style-type: none"> ● Connect RS 485 Bus again; ● Replace RS485 Bus; ● Add terminal matching resistance; ● Add RS485 distributor.

**Slight difference may be found in the user interface.
All the designs and software are subject to change without prior written notice.
Please visit our website for more information.**