

IR-908

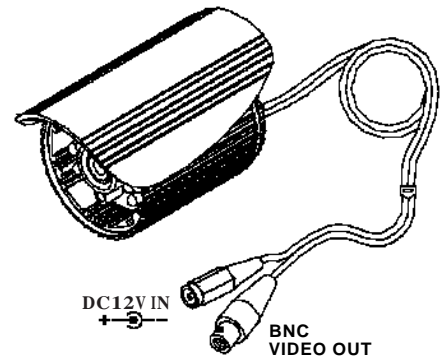

- 1/4" SONY CCD, 21pcs LEDS, IR distance up to 15M.
- Aluminum body, beautiful outline, excellent heat dissipation.
- Rear panel and upper sunshade are on one molding, with the most meticulous waterproof effect.

MODEL	IR-908	
VIDEO SYSTEM	NTSC	PAL
PICK UP ELEMENT	1 / 4" SONY CCD IMAGE SENSOR (INTER LINE)	
IMAGE SIGNAL PROCESS	DIGITAL SIGNAL PROCESSING SYSTEM	
LENS MOUNT	2.9 mm	
NUMBER OF PIXEL	510 (H) × 492 (V)	500 (H) × 582 (V)
PICTURE ELEMENTS	APPROXIMATELY 250K	APPROXIMATELY 290K
HORIZONTAL RESOLUTION	420 TVL	
POWER SUPPLY	DC 12V	
POWER CONSUMPTION	5.6 W	
SYNCHRONIZATION	INTERNAL	
SCANNING SYSTEM	2 : 1 INTERLACE	
SENSITIVITY	0 LUX (IR ON)	
S/N RATIO	Max. 48 dB	
AUTO GAIN CONTROL	YES	
BACK LIGHT COMPENSATION	AUTO	
WHITE BALANCE	AUTO	
ELECTRONIC SHUTTER	AUTO: 1/60 S TO 1/10000 S	AUTO: 1/50 S TO 1/10000 S
OUTPUT	1 Vp-p COMPOSITE VIDEO OUTPUT, 75Ω	
LEDS	21 PCS	
IR RANGE	15 M	
WAVELENGTH	850 nm	
POWER CONSUMPTION	70mA(IR OFF) / 260mA(IR ON)	
OPERATING TEMPERATURE	-10° C ~ +65° C	
DIMENSIONS (W × D × H)	Φ66×64× 104 mm	
WEIGHT	About 330g	

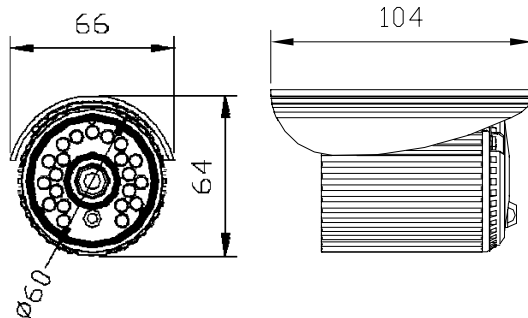